

Emergency 2-meter J-Pole Antenna Construction

- This is a club project for the Oak Forest Amateur Radio Club.
- The object of the project is to have you come away with a working antenna for your hand-held radio.
- The project will highlight the following:
 - Antenna principles
 - Construction practices
 - Soldering
 - Frequency measurement

Materials

- We plan to have materials at the meeting so you don't need anything except for your radio. If you want to get a jump on the project you can assemble some or all of the materials yourself.

Here is the equipment list:

- Your radio
- Wire cutter / stripper
- Soldering iron and solder
- 6-feet of 300 ohm TV twin lead antenna wire (enough for one 2-meter J-Pole) with some extra.
- 5-feet of RG58AU 50 ohm coaxial cable (stranded center). A "jumper" cable with male BNC connectors on both ends is best so we don't have to solder connectors to the cable.
- 12-inches of $\frac{3}{4}$ inch heat-shrink tubing.
- Female BNC to SMA connector to match your radio. BNC-male for Baofeng. BNC to female for others. (See figures)
- Female BNC panel mount connector (attaches to the antenna)



Female BNC to Female SMA
(Chinese Radios, Baofeng etc.)



Female BNC to Male SMA
Japanese and US radios



Male BNC 50 ohm patch cord



Female BNC panel mount
Attaches to feed point

10 watt power limit

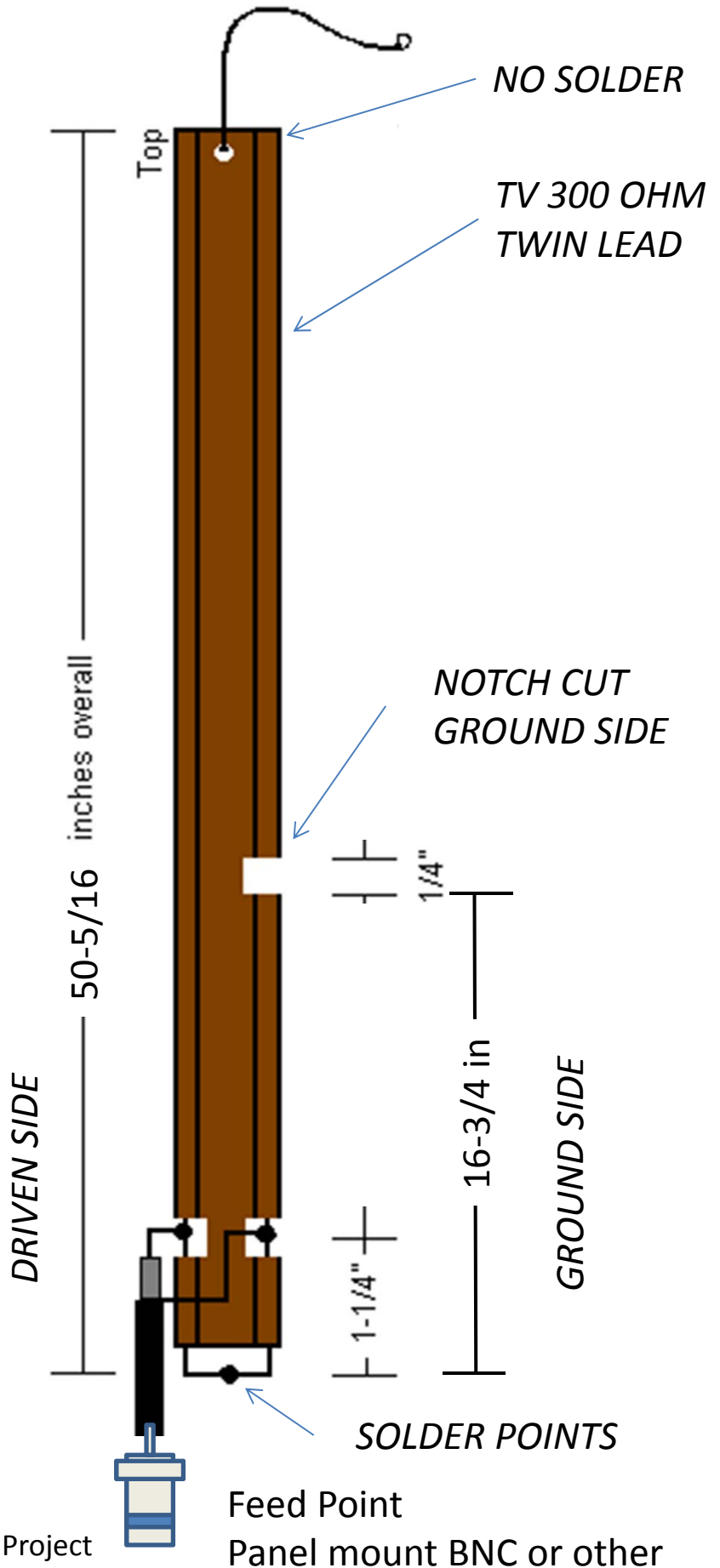

Example Wiring Layouts

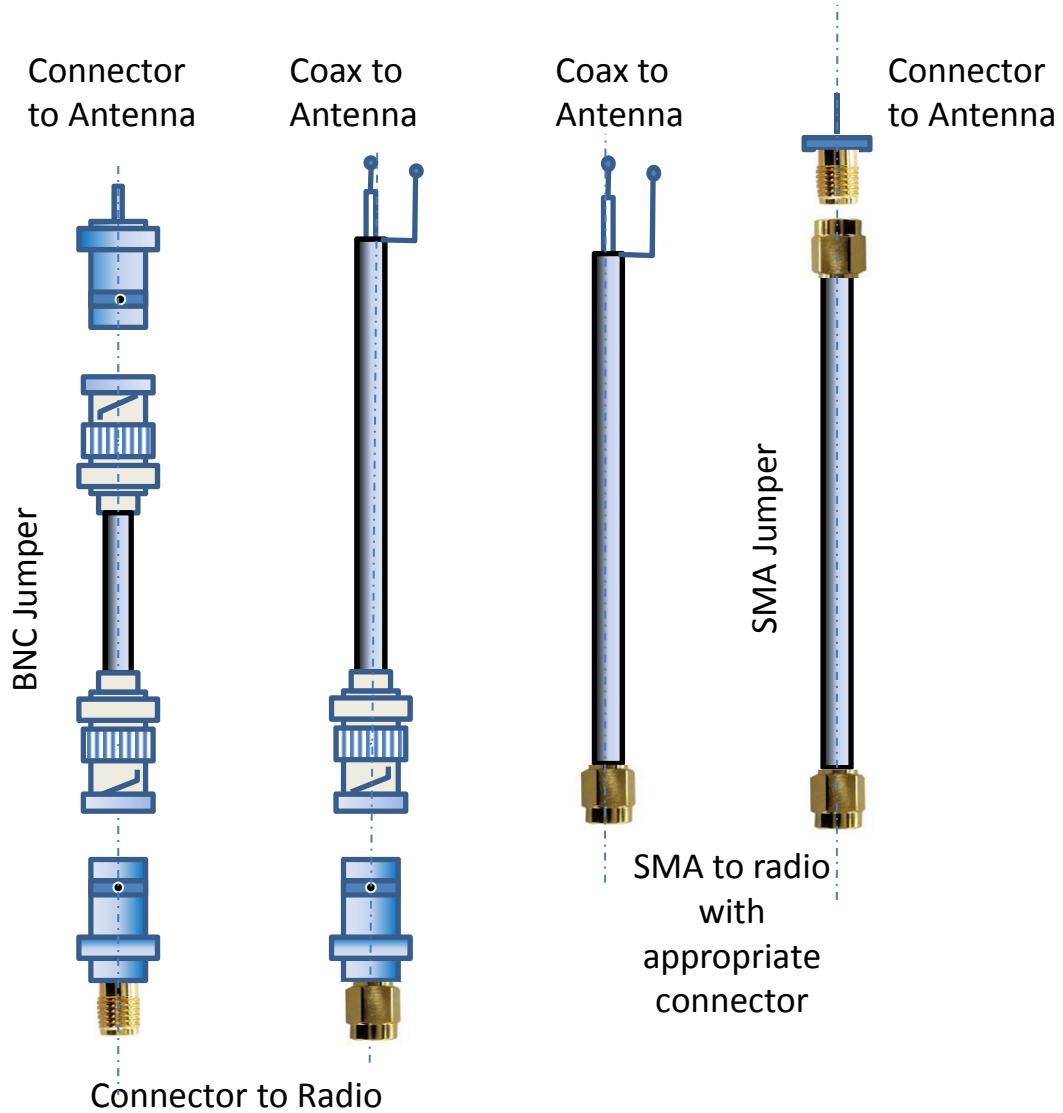

FYI – SMA = Subminiature Version A
BNC – Bayonet Neill Concelman

An Easy Dual-Band VHF/UHF Antenna

You've just opened the box that contains your new H-T and you're eager to get on the air. But the *rubber duck* antenna that came with your radio is not working well. Sometimes you can't reach the local repeater. And even when you can, your buddies tell you that your signal is noisy.

If you have 20 minutes to spare, why not build a low-cost *J-pole* antenna that's guaranteed to outperform your rubber duck? My design is a dual-band J-pole. If you own a 2-meter/70-cm H-T, this antenna will improve your signal on *both* bands.

Hams throughout the world have built and used J-pole antennas for years. My design is simple, lends itself to experimentation and alternative construction techniques, and has the following features:

□ A 1.7:1 SWR or better throughout most of the 2-meter band and less than 2:1 across the 70-cm band.

□ Easy set up. You can put it on the air in a matter of seconds, or store it in a space no larger than a small paperback book.

□ Simple construction. The entire antenna system can be built in less than 30 minutes using TV twin lead and coaxial cable.

Why settle for the performance your rubber duck antenna offers?

Build this portable J-pole and boost your signal for next to nothing!

By Jim Reynante, KD6GLF
PO Box 27856
San Diego, CA 92198

All of the SWR data in this article was measured at the transmitter end of the feed line. The reference impedance is 50 Ω, since most equipment is designed for this impedance.

J-Pole Antenna Theory

The J-pole is a vertically polarized antenna with two elements: the radiator and the matching stub. Although the antenna's radiator and stub are $\frac{3}{4}$ wavelength and $\frac{1}{4}$ wavelength, respectively, it operates as an end-fed half-wave antenna. Here's how you determine the lengths of the J-pole's two elements:

$$L_{3/4} = \frac{8856 \times V}{f}$$

$$L_{1/4} = \frac{2952 \times V}{f}$$

where:

$L_{3/4}$ = the length of the $\frac{3}{4}$ -wavelength radiator in inches

$L_{1/4}$ = the length of the $\frac{1}{4}$ -wavelength stub in inches

V = the velocity factor of the TV twin lead
 f = the design frequency in MHz

These equations are more straightforward than they look. Just plug in the numbers and go. My design assumes that 146 MHz is the center frequency on the 2-meter band. You may, of course, substitute a center frequency of your choice. Even though the antenna is designed using a 2-meter center frequency, it also works well on 70 cm—as you'll see later.

Don't let the *velocity factor* throw you. The concept is easy to understand. Put simply, the time required for a signal to travel down a length of wire is *longer* than the time required for the same signal to travel the same distance in free space. This delay—the velocity factor—is expressed in

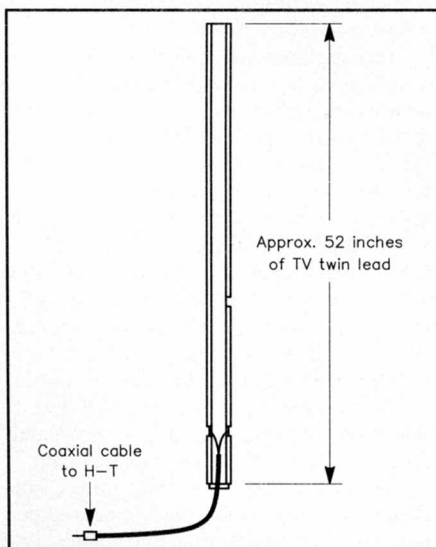

Figure 1—The J-pole antenna is approximately 52 inches long and may be hung from just about anywhere.

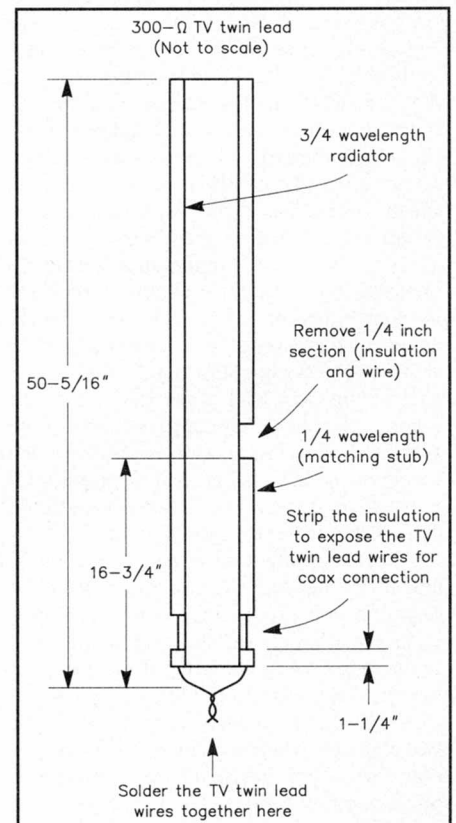

Figure 2—The basic J-pole layout. Note the areas where insulation and/or wire must be trimmed.

terms of the speed of light, either as a percentage or a decimal fraction. Knowing the velocity factor is important when you're building antennas and working with transmission lines. Because of the delay, 360° of a given signal wave exists in a physically shorter distance on a wire than in free space. This shorter distance is the *electrical* length, and that's the length we need to be concerned about.

Copper wire has a velocity factor of about 0.93, whereas TV twin lead has a velocity factor of 0.81 to 0.85 depending on who made it. If you're unsure about the twin lead you're using, just use 0.85 as its velocity factor. It's okay if it turns out to be too high. You'll be able to compensate by trimming the antenna. (It's better for the antenna to be too long than too short!) The TV twin lead I used had a velocity factor of 0.83. So, using the formulas, at 146 MHz the lengths would be approximately 50⁵/₁₆ inches for the 3/4-wavelength radiator and 16³/₄ inches for the 1/4-wavelength stub.

Construction

Because of the few materials needed to construct this antenna, you'll find it surprisingly easy to build. Start with approximately five feet of 300-Ω TV twin lead and about six feet of 50-Ω coaxial cable (see Figure 1) with a suitable connector (most H-Ts use a BNC connector). Use only flat 300-Ω TV twin lead, not foam core. RF can potentially short through the foam core.

Start by stripping off 1/2 inch of insulation at one end of the TV twin lead (see Figure 2). Solder the two exposed wires together. This is the bottom of the antenna. Next, measure up 1 1/4 inches from the soldered wires and remove the insulation from the twin lead to expose 1/8 to 1/4 inch of wire on both sides. Be careful not to nick or break these wires. They are your connection points for the coaxial feed line.

Now you're ready to measure and cut the elements of the antenna. On one side of the twin lead, measure up 50⁵/₁₆ inches from the center of the exposed wire and trim off the twin lead entirely (both conductors). This side of the twin lead is the radiator of the J-pole antenna. On the opposite side of the twin lead, measure up 16³/₄ inches from the center of the exposed wire and carefully remove a 1/4-inch section of insulation and wire. This is the 1/4-wavelength matching stub.

Turn your attention to the coaxial cable and strip the end without the connector. Separate and expose the center conductor from the braided shield. Attach the coax to the twin lead by soldering the center conductor of the coax to the longer element of the J-pole and the shield to the shorter of the two elements. Do this at the point where you removed the twin lead insulation and exposed the wire on both sides (see Figure 3).

Apply a generous amount of weather-proof silicon sealant to the exposed coax to prevent moisture from seeping into the line. Now tape the coax to the twin lead to relieve

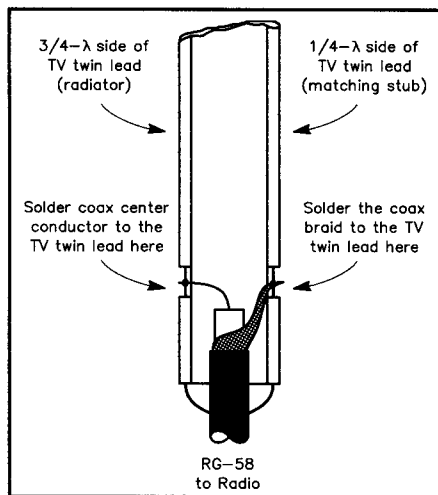

Figure 3—The coaxial feed line is connected directly to the antenna. Be careful to observe that the center conductor is soldered to the side of the TV twin lead with the longer conductor. The braid is connected to the side with the shorter conductor.

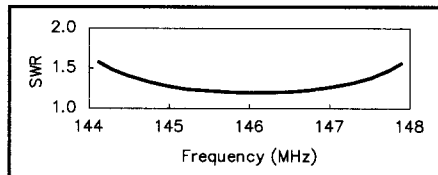

Figure 4—The SWR of the J-pole over the 2-meter band.

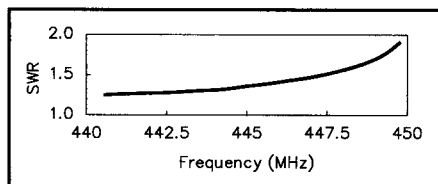

Figure 5—On the 70-cm band, the J-pole still presents a useable SWR.

strain on the soldered connection points. Heat shrink tubing also works well for this application.

Tuning

Hang your J-pole vertically by making a small hole at the top of the antenna and tying a length of twine or fishing line. Take care to keep the antenna away from metal objects that could detune it.

Tuning the J-pole is easy. Using a high-accuracy VHF/UHF SWR meter (borrow one if necessary), simply trim the length of the elements until you read a 1:1 SWR—or as close as you can get. Trim in *very* small increments; don't chop off an inch at a time! Remember to trim in a 3:1 ratio to maintain the 3/4- to 1/4-wavelength proportions. For example, if you cut 1/8 inch from the 1/4-wavelength stub, you must cut 3/8 inches from the 3/4-wavelength radiator (1/8 × 3 = 3/8).



I should mention that this design can cause RF coupling to the feed line. To avoid this, you can place ferrite beads on the coax at the feedpoint. An alternative is to use 3 to 5 turns of coax (1 to 2 inches in diameter) to create an RF choke at the feedpoint.

Results

Figure 4 shows my SWR measurements on 2 meters. As you can see, the antenna displayed a fairly flat SWR over most of the 2-meter band. At no point did it exceed 1.7:1. I achieved slightly higher, but useable, results on 70 cm (see Figure 5).

After hanging my J-pole from a tree limb and connecting my H-T, I switched to the frequency of a nearby repeater and gave it a try. I was able to talk with several local hams and they all said my signal sounded strong and clear. So far so good, but now came the true test. I switched to a repeater located about 17 miles north of my home, one that I couldn't use with my rubber duck antenna. I keyed the transceiver, announced my call sign, and was almost immediately greeted by a friendly voice. It worked! And not only that, it worked pretty well. The other ham said I was full-quieting into the repeater. Not bad for less than 30 minutes of work. Reception performance was also improved.

Summary

A J-pole antenna will never replace a beam or a full-size vertical mounted at 30 feet, but it offers relatively good performance for a minimum of materials, time and effort.

The applications of this antenna go beyond emergency or portable use. A permanent weatherproof enclosure can be built by mounting the J-pole inside a length of PVC tubing capped at the top. The PVC tube may then be placed at the top of a mast or similar structure. You can drill a small hole in the side of the PVC tube for the coax. Just make sure to seal it against the weather. The PVC will protect the antenna and can be painted to match the color of your house or apartment. If you live in an area where you can't put up outside antennas, hang the J-pole in your attic! If the antenna is located more than 10 feet from your radio, use a low-loss coaxial feed line such as RG-213 or equivalent.

Because of the low cost, simple construction, compact size and improved performance, there's no reason not to build several of these antennas. Keep one rolled up in your backpack when hiking, or in the glove compartment of your car! **QST**

Q: I built the dual-band J-pole antenna from the article in the September 1994 *New Ham Companion* (“An Easy Dual-Band VHF/UHF Antenna,” page 61), but I just can’t get it to work. What can I do?

A: Try adding a balun to the coax. A balun is necessary because a J-pole antenna uses a balanced feed (the 1/4-wavelength matching section) connected to an unbalanced feed line (the coax). The simplest way to make a balun is to get a split-core cylindrical ferrite (such as an Amidon 2X-43-251) and attach it to the outside of the coax 1/4 wavelength from the feedpoint. On VHF frequencies some ferrite materials are not effective, so be sure to get type 43 material for best results.

Another thing you may want to do is lengthen the antenna a bit. The formula for the antenna length in the article is unintentionally misleading. Because the 1/2-wavelength radiator is not a feed line, it has a much higher velocity factor than that of twin lead. The velocity factor of copper wire is about 0.95, so the 1/2-wave radiator section should be 38-3/8 inches long.